



Single Sector Cell Extender System— 200W MCPA Unit 850 CDMA

Tel: +1 201 342 3338 Fax: +1 201 342 3339 Email: sales@cciproducts.com

Overview

▶ CCI Models: MCS850-200 and DTMA08FG12



Maximize Network Performance and Increase Revenue

The pressure on Network Operators to maximize the assets and increase revenue means that increasing capacity and coverage is a key driver. However, there are often constraints such as tower loading, planning permission, high cost of leasing, and installation issues. All of which are difficult to implement, take too much time, and are expensive to overcome. Cell Enhancers can overcome these issues, and lead to increased **quality, coverage, capacity and revenues.**

CCI offers a single sector Cell Extender comprising a compact high power 200W MCPA product which boosts the Downlink for multiple carriers and with a Twin TMA can provide fully link-balanced increase in coverage and capacity. CCI's Multi-Carrier Amplifier System breaks with traditional integration concepts and sets a new direction with a seamlessly integrated **direct mounting systems.** Derived from our SCPA product line, the MCPA comes in a lightweight frame that enables it to be mounted easily in small space, requiring no dedicated pad/floor space, saving valuable deployment time and cost.

The system employs a new highly efficient MCPA design that is an integral part of CCI's complete turn-key MCPAsystem. High power density of the MCPA module and power plant create a powerful compact package. The MCPA system supports multiple simultaneous formats such as GSM/EDGE, CDMA1X/DO, and UMTS. Multiple radios are combined on high capacity sites to reduce the required number of feeders without impacting coverage.

CCI's MCPA is a key element in upgrading or cositing existing (growth) or new base stations, and can be expanded to add new MCPA modules as the carriers increase.

Features and Benefits

- The 200W MCPA is system is a simple plug and play unit, with the benefit of handling active Tx from both ports of the BTS
- BTS inputs then are duplexed, combined, amplified, then re-duplexed to the antenna
- MCPA produces a full 200W output power, and that is divided between the number of carriers—that is at least 6dB increase on a standard BTS output
- Future proof—If carrier count increases in the future, an additional MCPA module can be added to maintain original power levels per carrier.
- Balanced link budget with 12dB Twin TMA—a Twin unit for outdoor use
- All Power supply and Bias-T included with the MCPA package solution
- Requires standard AC power, (not HVAC) AC –DC Rectifier module has circuit breakers
- Low Maintenance, highly reliable unit, fans hot swappable
- Very low intermodulation distortion
- Highly efficient MCPA, with auto boot feature which reboots automatically if power interruption



AC-DC Rectifier



MCPA Module

Rapid Capacity and Coverage Expansion at minimal cost: Full Utilisation

Full 200W Power

Highly Reliable

Multi-carrier

TMA included

AC Feed

Indoor Compact Unit

Fully Expandable

Dual Tx BTS ports

Implementation Schematic

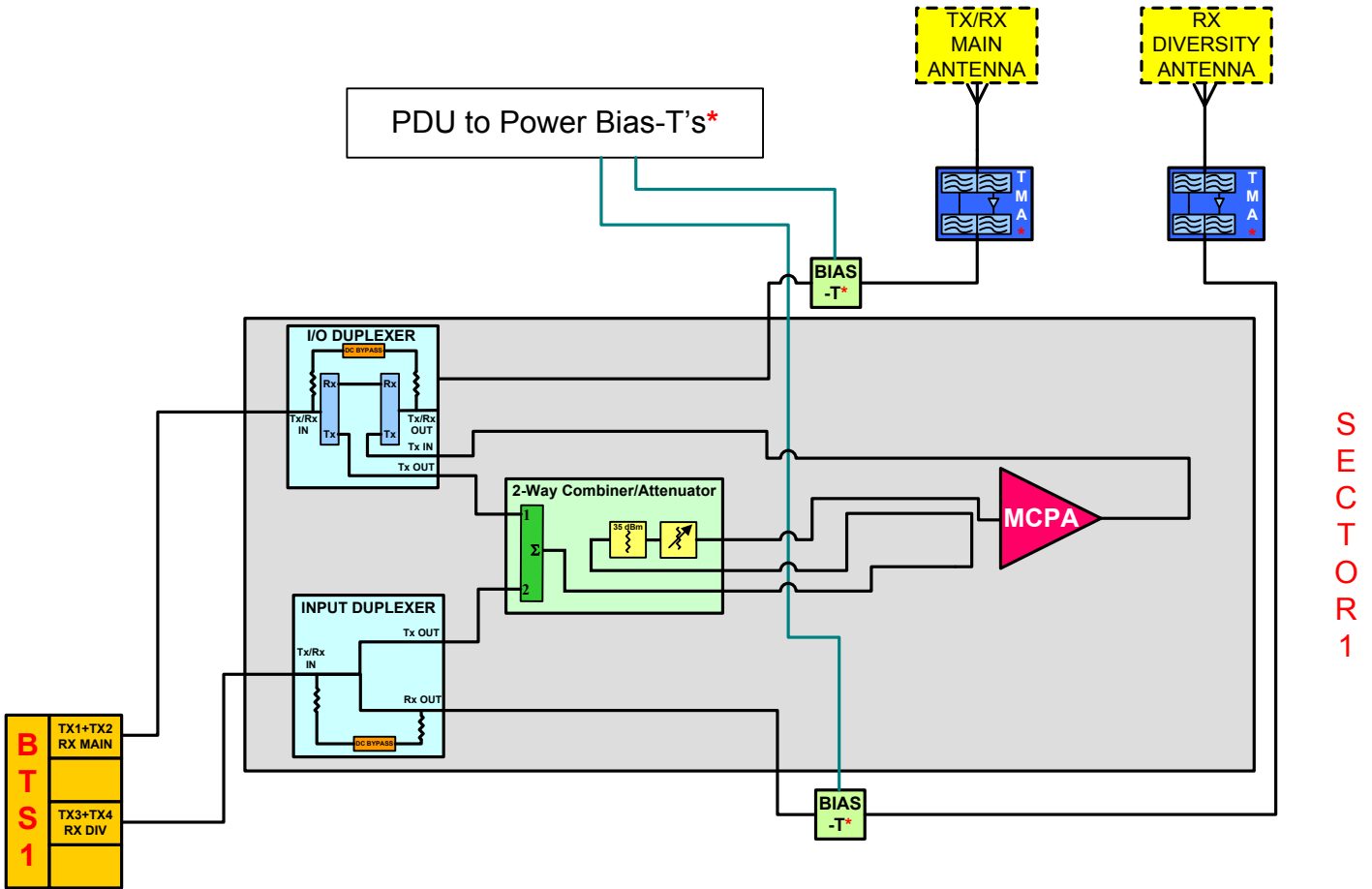

*Items including PDU to Power Bias-T, Bias-T, TMA are Included with MCPA solution for Uplink improvement

Implementation

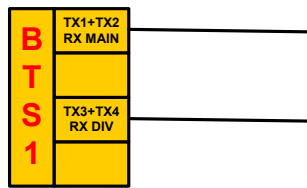

Composite Power 50W from BTS
4 Carriers approx 12W per carrier

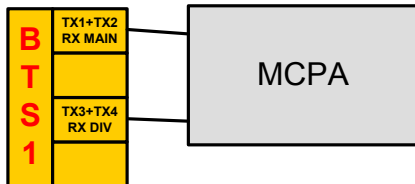

Composite Power 200W from MCPA
4 Carriers approx 50W per carrier

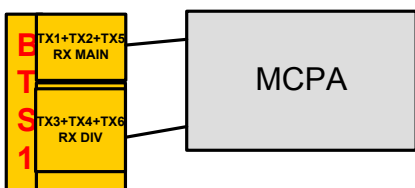

Composite Power 200W from MCPA
6 Carriers approx 33W per carrier

With the MCPA in place, the total power output to the main feeders is 200W

All the carriers at the BTS are combined and amplified to the 200W total output power. Thus the 200W is divided by the number of carriers to find the power level per carrier

In this scenario, the MCPA effectively is giving the Downlink an additional 6dB of gain, and a 12dB TMA is balancing this on the Uplink

Feeder losses are low at 850MHz, so should be less than 1dB, a loss that was always there even without MCPA

At 8 carriers, it could be beneficial to add additional MCPA module to restore all carriers to 50W each

CDMA Multi-Carrier Cell Extender System Level Specifications

Description	Typical Specifications	
Electrical	Forward Link (Downlink)	Reverse Link (Uplink)
Frequency range of operation	869 - 894 MHz (U.S. Cellular Band)	824 - 849 MHz (U.S. Cellular Band)
Usable Composite Output Power	200 Watts (Referenced to PA Module Output connector)	
Operational Bandwidth	25 MHz (869 - 894 MHz)	
System Gain	Adjustable to 13 dB in 0.5 dB steps - via Software	16 dB - Std. TMA
	Adjustable to 13 dB in 1 dB steps - via DIP Switch	15 dB - TMA with SMRR Option
Gain Variation	± 0.75 dB Max.	± 0.5 dB Max.
Passband Flatness	± 1.0 dB Max.	± 0.5 dB Max.
Harmonics and In-Band Emissions	-13 dBm Max. (FCC emissions limits)	N/A
System Group Delay	180 nSec Max.	
Input/Output VSWR	1.5:1 Max.	1.5:1 Max.
Up-Link-Down-Link Isolation	90 dB	
Uplink Noise Figure		1.5 dB Typ. - Std. (Referenced to Antenna Port, with TMA)
		1.7 dB Typ. - SMRR (Referenced to Antenna Port, with TMA)
Power Supply Voltage	+21V DC to +28V DC (+27.0V DC nominal, +25.5 to +28.0V DC meeting all specifications)	
Input Power Options	+27 VDC PDU (+26 to +28 VDC)	
	220 VAC (AC PPS) Battery Backup Optional	
DC Current Draw	46 Amps Max per PA Module (At nominal voltage and Max Rated Pout)	
Power Consumption	1.5 KW Max. per Sector @ 27 VDC (46A DC @ +27 VDC/Amplifier)	

Communication Components Europe Ltd

19 Rodney Road
Cheltenham
GL50 1HX
UK

Tel: +44 7721 632636
Email: sales@cciproducts.com

Communication Components Incorporated

89 Leuning Street
South Hackensack, NJ 07606
USA

Tel: +1 201 342 3338
Fax: +1 201 342 3339
Email: sales@cciproducts.com



CCI Cell Extender Module

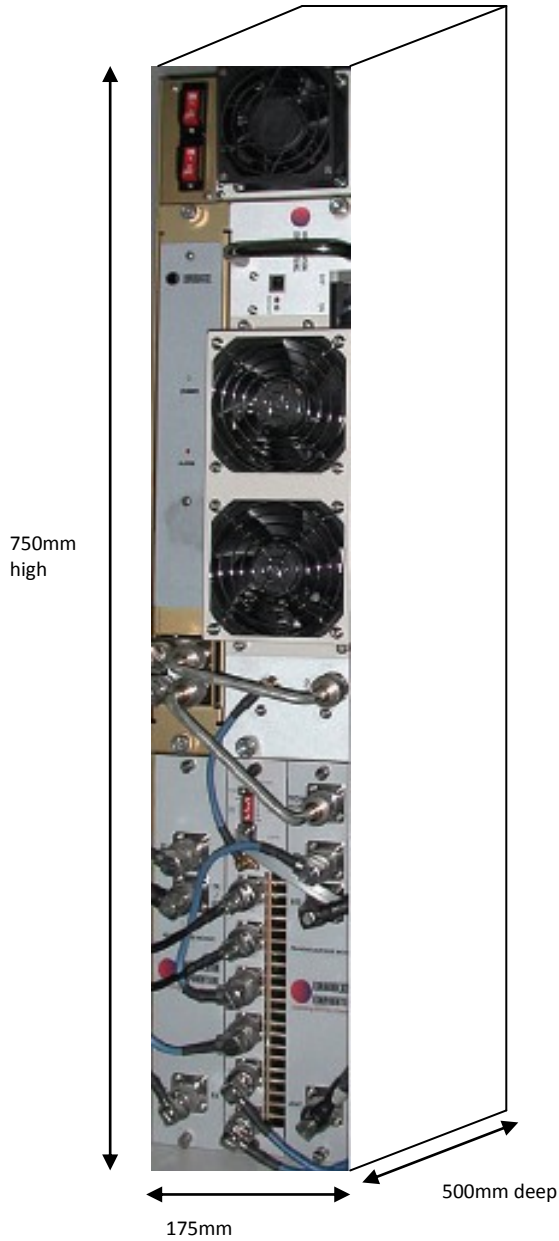

MCPA Module—850 CDMA 200W—single sector

Housed in simple tray for indoor use within shelter, so can then be easily positioned close to the BTS equipment

Weight ~35kg